

RM Series In-built Battery Modular Online UPS 20-60kVA (380V/400V/415V)

RM060/20B series are modular online UPS with hot-swappable battery. The single cabinet power rating covers from 20kVA to 60kVA which delivers the best of combination of reliability, hot-swappable and flexibility.

With intelligent battery protection and management technology, RM060/20B realises a compact total power solution which is easy for installation, maintenance and power expansion.



Features

- Modular design with swappable battery package
- Monitor system for battery
- Integrated IGBT module with improved performance and reduced size
- Easy for installation and maintenance
- Easy for power expansion and backup time expansion
- Intelligent protection technology for safe and reliable hot swappable battery package of the system
- Smart charging management system, intelligently control the whole process of the charging and discharging, effectively improving the life time of the battery
- Battery cold start
- Friendly human machine interface with touch screen

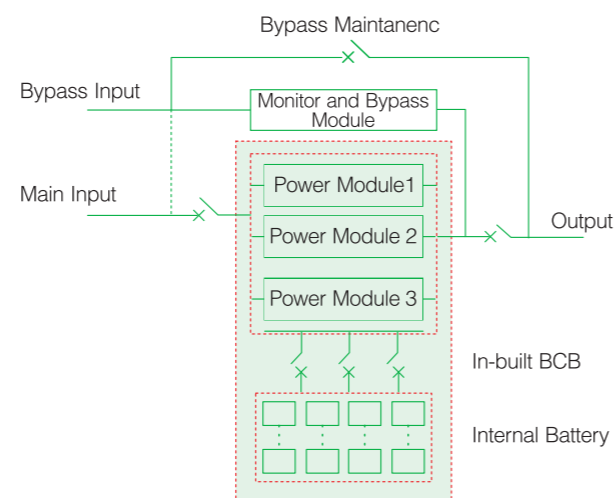

Specification

MODEL	RM060/20B (In-built Battery)	
Capacity	60kVA/54kW	
Power module	PM20(20kVA/18kW)	
INPUT		
Phase	3 Phase + Neutral + Ground,380V/400V/415V(line to line)	
Voltage range	-20%-25%	
Frequency range	40Hz-70Hz	
Power factor	>0.99	
THDi	THDi<3% @100% linear load	
OUTPUT		
Voltage regulation	1.5%	
THDu	THD<1%(linear load),THD<5.5%(non-linear load)	
Power factor	0.9	
Crest factor	3:1	
Overload capability	110% for 1 hour; 125% for 10 min ;150% for 1 min; >150% for 200 ms	
BATTERY		
Voltage	±240VDC	
Charge power	20%*System Power	
Charge power precision	±1%	
SYSTEM		
System efficiency	Normal mode:95%;ECO mode:98%; Battery mode:95%	
Display	LCD+LED, Touch Screen +Keyboard	
IP class	IP20	
Interface (Communication port)	Standard:RS232,RS485,Dry contacts; Optional: SNMP	
Installation/Connection	Top or bottom cable connection	
Operation/Storage temperature	0-40°C/-40-70°C	
Relative humidity	0-95%(non-condensing)	
Noise	55dB(1 meter away)	
PHYSICAL		
Weight	Cabinet	205kg;
	Power Module	PM20:22kg
	Battery package	10kg(without battery)
Dimension (W*D*H) (mm)	Cabinet	600*1020*2000
	Power Module	PM20/PM15/PM10:440*590*134
	Battery package	120*824*177