

Preface - About Products and the Manual

[Manual Use]

The manual introduces the main features, performance and working principle of the new generation intelligent integrated rack precision air conditioner, and provides users with information such as use, operation and maintenance.

[Use Objects]

Technical support engineer

Service engineer

[Exemption Clauses]

1. Beyond the free warranty period;
2. Dismantling or modifying products without authorization;
3. Violation of product operation or use specifications;
4. Man-made fault;
5. Loss caused by force majeure or other external factors on the client side.

[Note: Any of the above exemption clauses will not be covered by warranty.]

[Related Descriptions]

1. This manual is provided with the product. Please keep it properly so that you can check it at any time when necessary. In case this manual is accidentally lost or damaged, please ask the manufacturer or local distributor directly.
2. This manual is written for VCS series air-cooled integrated rack precision air conditioner products, and the contents are not necessarily applicable to other models;
3. Due to product version upgrade or other reasons, the contents of this manual will be updated irregularly. Unless otherwise agreed, this manual is only used as a guide, and all statements, information and suggestions in this manual do not constitute any express or implied guarantee.
4. The copyright of this manual belongs to INVT Network Power (Shenzhen) Co., Ltd. with all rights reserved. Any changes to the contents shall not be noticed otherwise.

Content

Chapter 1 General Introduction	4
1.1 Product Introduction.....	4
1.2 Operating Parameters and Requirements	4
1.3 Model Description.....	5
1.4 System Composition	5
1.5 Product Specifications.....	6
1.5.1 External Specification and Net Weight	6
1.5.2 External Structure	6
1.6 Airflow Direction	8
Chapter 2 Receiving.....	10
2.1 Transportation	10
2.2 Product Receiving	10
2.2.1 Suggestions on Receiving Process	11
2.2.2 External Inspection	12
2.2.3 Unpacking.....	12
2.2.4 Internal Inspection	13
2.2.5 Storage	13
Chapter 3 Installation.....	14
3.1 Installation Place	14
3.2 Mechanical Installation	15
3.2.1 Installation Mode.....	15
3.3 Installation of Other Components	18
3.3.1 Installation of Sealing Assembly.....	18
3.3.2 Installation of the Drainage Pipe	18
3.4 Electrical Installation.....	19
Chapter 4 Controller	22
4.1 Functions and Characteristics.....	22

4.2 Display Screen.....	22
4.3 Control Keys	23
4.4 Power-on/off Operation.....	24
4.5 Status Query	24
4.6 User Setting	24
4.7 Input/output View	25
4.8 Operation Logic.....	26
Chapter 5 Inspection and Commissioning	28
5.1 Inspection	28
5.2 Function Inspection	28
Chapter 6 Maintenance and Fault Treatment.....	29
6.1 Daily Maintenance	29
6.2 Treatment of Common Faults	29
Annex I Electrical Schematic Diagram	33

Chapter 1 General Introduction

Summary - This Chapter mainly covers five parts: product introduction, operating parameters and requirements, model description, system composition and product specifications.

1.1 Product Introduction

About the Product

VCS series integrated rack precision air conditioner is a product which is highly suitable for the application scenarios of micro-module products. Embedded in the standard cabinet, it can realize the near-end refrigeration without an external machine and reduce the PUE value of the data center. It has the characteristics of high efficiency, energy saving, simple installation, high integration, safety and reliability.

Model

The main functions of this product are: refrigeration function and heating function.

Refrigerating Capacity

The refrigeration grade of VCS series integrated rack precision air conditioner is 3.5kW.

Characteristics

1. Integrated design of internal and external machines, simple installation with plug and play;
2. High reliability, high sensible heat ratio and large air volume;
3. Rack design concept makes the layout application more flexible and delicate;
4. R410A green and environmental protection refrigerant is adopted, which meets the international green and environmental protection requirements;
5. The design of large area evaporator and condenser is adopted, which makes heat exchange faster and more efficient;
6. The compressor of international famous brand is adopted, whose excellent quality ensures the high efficiency and stability of the unit;
7. High-quality refrigeration devices are adopted so the operation is more reliable;
8. The device is stable with low failure rate and convenient maintenance;
9. It is equipped with 485 interface and supports remote monitoring and other functions.

1.2 Operating Parameters and Requirements

Table 0-1 Table on Operating Parameters and Requirements

Operating parameters	Temperature	0°C~45°C
	Humidity	5%~95%RH

Operating requirements	Altitude	Altitude is $\leq 1000\text{m}$, and it needs derating if it is greater than 1000m
	Power	Single-phase 220V/50Hz or single-phase 220V/60Hz (different frequencies correspond to different models)

1.3 Model Description

For example: Model - VCS003UH****

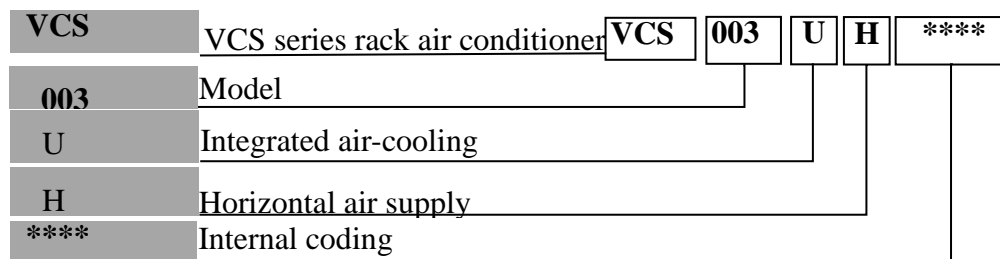

Fig. 0-1 Naming Rules of Integrated Rack Precision Air Conditioner

1.4 System Composition

VCS series integrated rack precision air conditioner is mainly composed of refrigeration system, control system, ventilation system and heating system. The unit is mainly composed of the following components:

1. Compressor - high-efficiency compressor and R410A refrigerant are adopted, which is green, environment-friendly and pollution-free;
2. Evaporator - be designed with internally threaded copper pipe and large-area hydrophilic windowed aluminum foil to make heat exchange faster and more efficient;
3. Condenser - be designed with internally threaded copper pipe and large-area windowed aluminum foil to make heat exchange faster and more efficient;
4. Heater - PTC heater with fast heating speed and uniform heat;
5. Filter - protect the refrigeration system so that the system operation is not affected by impurities;
6. Fan - a backward tilting centrifugal fan with large air volume and high reliability is adopted;
7. Air filter screen - filter dust and impurities in the air to ensure the cleanliness of the environment;
8. Controller - equipped with standard RS485 communication interface, which supports remote centralized control, power on auto-start, password protection and timing on/off, etc.

1.5 Product Specifications

1.5.1 External Specification and Net Weight

Table 0-2 Appearance Specification and Net Weight

Model	External dimension (mm) W×H×D	Net weight (kg)
VCS003UH****	445×352×980	58

[Note: W-width; H-height; D-depth]

1.5.2 External Structure

The external structure of the whole machine is shown as the following figure.

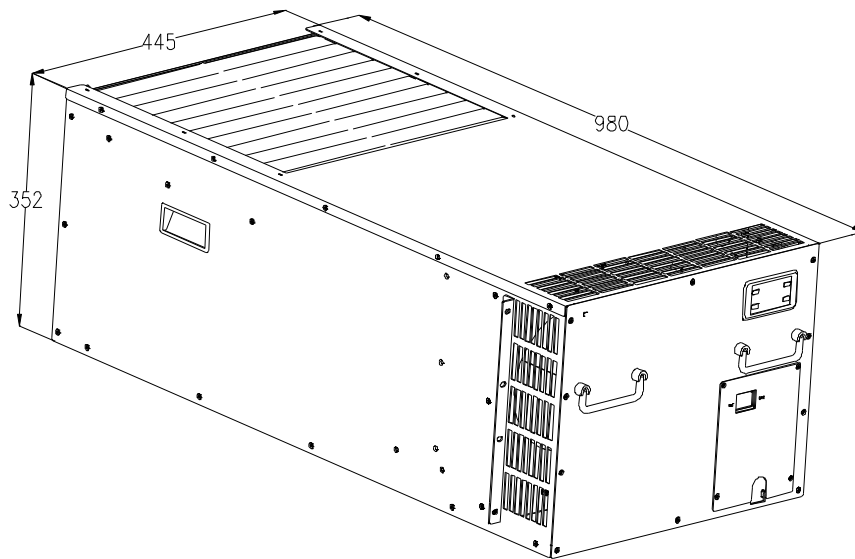

Fig. 0-2 External Specification Drawing of VCS003UH

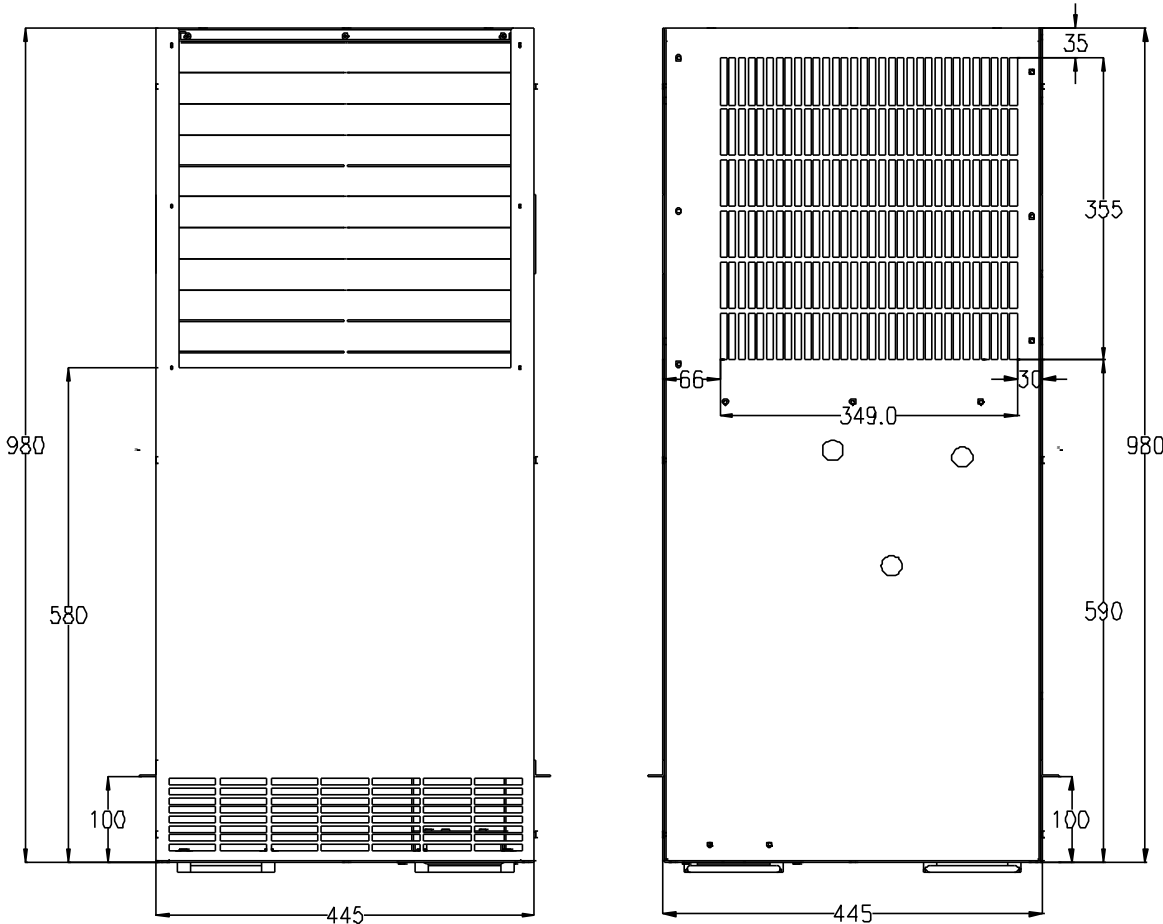
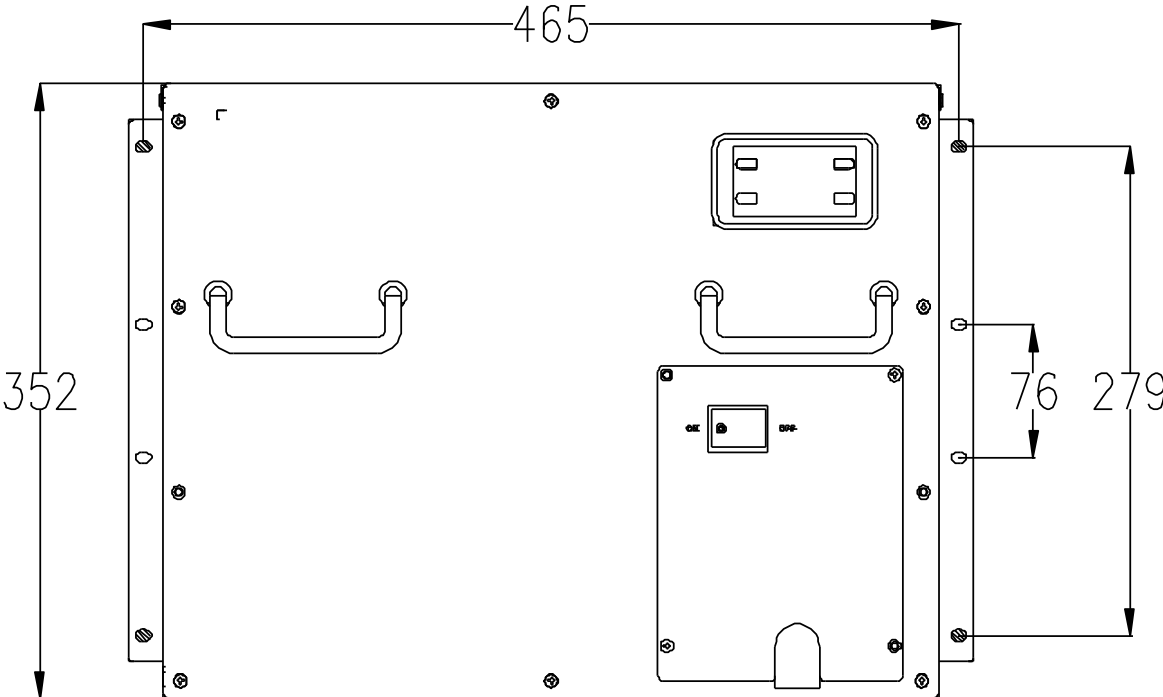

Fig. 0-3 VCS003UH Top/Base Plate (Left: Top Plate Right: Base Plate)



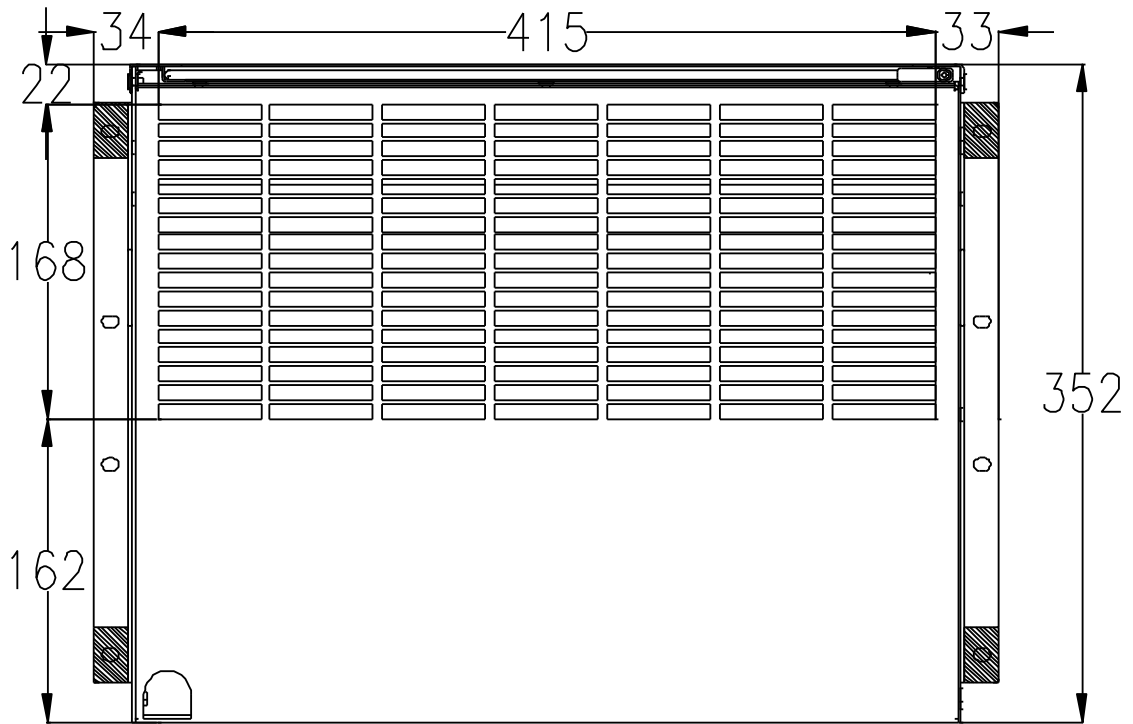

Fig. 0-4 VCS003UH Front/Rear Cover Plate (Up: Front Cover Plate Down: Rear Cover Plate)

1.6 Airflow Direction

See Fig. 1-5 for the inlet/outlet airflow direction of VCS003UH internal circulation; see Fig. 1-6 for the inlet/outlet airflow direction of VCS003UH external circulation.

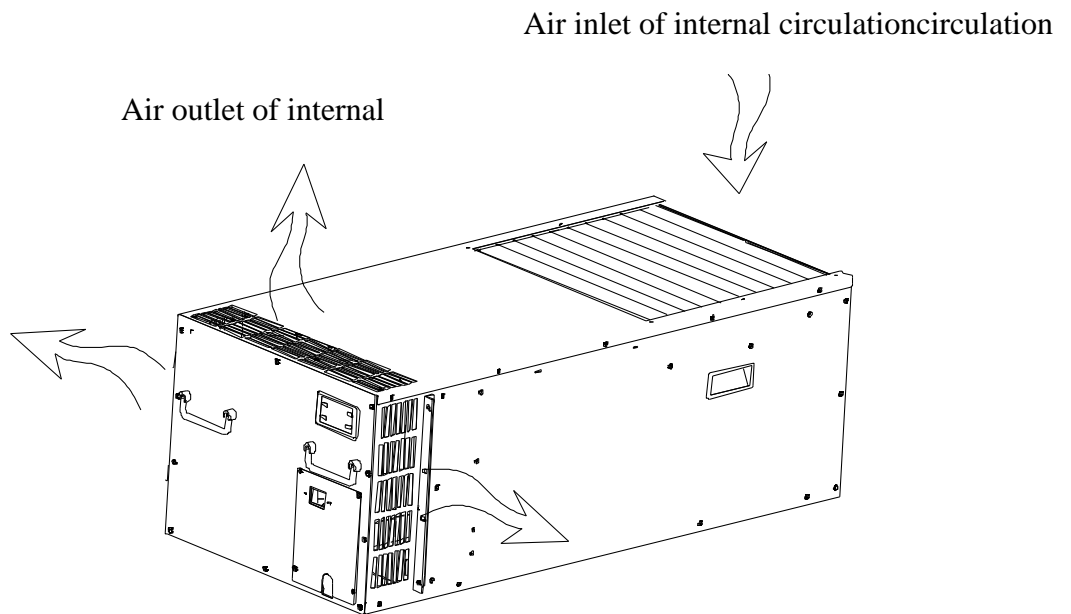
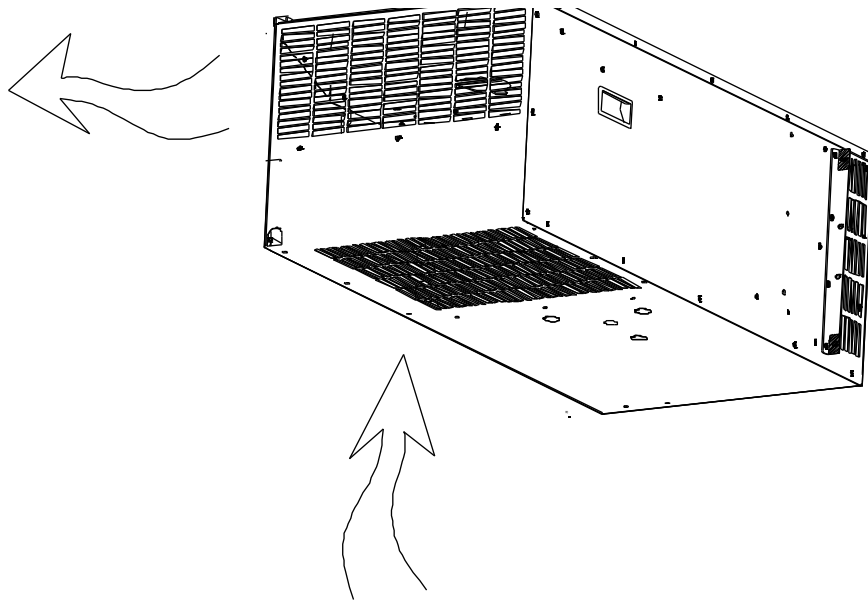

Fig. 0-5 Diagrammatic Sketch of Airflow Direction of Internal Circulation

Air outlet of external circulation



Air inlet of external circulation

Fig. 0-6 Diagrammatic Sketch of Airflow Direction of External Circulation

Chapter 2 Receiving

Summary - This Chapter mainly introduces the process and related precautions in the process of product transportation and receiving.

2.1 Transportation

About the Product

The VCS series integrated rack precision air conditioner contains mechanical, electrical and other equipment, so improper transportation and handling may result in product damage and equipment failure. Please ensure product safety and quality during transportation and handling.

Precautions

Precautions in transportation and handling:

1. Please try to choose a better mode of transportation (such as railway transportation and shipping). When choosing automobile transportation, please choose road with good road conditions to prevent excessive bumps;
2. Transportation environment and placement requirements shall be implemented according to relevant requirements;
3. Please use mechanical handling tools as much as possible when unloading and handling, and the air conditioner must be placed upward. It is strictly forbidden to tilt or invert excessively;
4. Prevent collision and rainfall.

Table 0-1 External Packaging Dimension and Gross Weight of VCS Precision Air Conditioner

Product model	Packaging dimension (mm) W×D×H	Gross weight (kg)
VCS003UH****	550×460×1095	62

[Note: W-width; H-height; D-depth.]

2.2 Product Receiving

About the Product

The VCS series integrated rack precision air conditioner has passed strict quality assurance test and inspection before delivery. Please carefully check the equipment when receiving the products to ensure that the equipment is not damaged during transportation.

When the VCS series integrated rack precision air conditioner is shipped with the cabinet together, there is no packaging box; therefore, the following instructions on external packaging

inspection and unpacking operation are only applicable to packaged products.

2.2.1 Suggestions on Receiving Process

In view of the fact that after the products arrive, users have two choices: install it immediately and do not install it temporarily. In order to provide users with a better receiving scheme, the following simulated receiving process is given for users' reference. Please choose the best scheme according to the specific situation.

Schematic flow diagram

Fig. 2-1 below is a simulated schematic diagram of receiving process. See this section for details of each step.

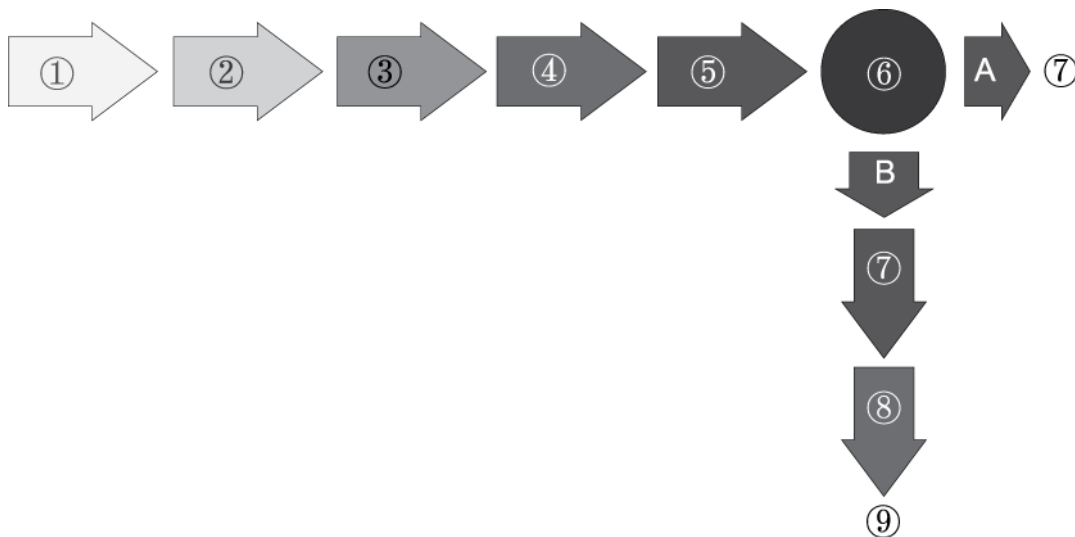

Fig. 0-1 Simulated Schematic Diagram of Receiving Process

The figure shows the receiving process under two conditions, namely Condition A and Condition B respectively;

Among which: A - install it immediately;

B - do not install it temporarily.

In Fig. 2-1: ① - product arrival;

② - external inspection;

③ - transportation;

④ - unpacking;

⑤ - internal inspection;

⑥ - acceptance;

A: ⑦ - complete receiving.

B: ⑦ - packing; ⑧ - storage; ⑨ - complete receiving.

2.2.2 External Inspection

Transportation Inspection

Upon arrival, check whether the transportation meets the transportation requirements.

Transportation requirements:

1. No rainfall;
2. Put vertically;
3. No stacking;
4. Be careful of collision.

[Note: The specific requirements shall be subject to the packaging requirements.]

External Inspection

The contents of external inspection include external product packaging and product exterior, etc.

Inspection contents:

1. Whether the external packaging has been unpacked;
2. Whether the external packaging has obvious damage and collision marks;
3. Whether the exposed parts of the equipment are damaged, such as structural deformation and falling off of the finish, etc.;

Related Tips

1. If it is found that it has been opened, please check whether there is any information prompt on the bill of lading or other aspects; if not, please contact the relevant departments;
2. If damage is found, please indicate the corresponding damage on the bill of lading and submit the damage claim to the transportation company;
3. The above problems may cause damage to the product and equipment, which makes the product unable to be used normally, so please check it carefully. If there is any problem, please contact INVT Service Department.

2.2.3 Unpacking

Suggestions

1. It is recommended that users carry the products to the installation site as close as possible (or to the storage place) before unpacking;
2. When unpacking, users are advised to consider the reusability of the packing box.

Related tips

1. The product is packed in cartons, and users must be careful when unpacking, so as to avoid the equipment damage and abnormal use caused by improper operation;

2. Improper human operation may cause damage to the equipment, resulting in invalid warranty of the manufacturer.

2.2.4 Internal Inspection

Inspection Contents

1. After unpacking, please carefully check whether all parts inside the equipment are complete and damaged;
2. Check whether the accessories are complete according to the packing list.

Related Tips

1. If any parts are found missing or damaged during inspection, it shall be reported to the carrier immediately; if hidden damage is found, please report it to the carrier and product supplier;
2. If the packing list is incomplete, please contact the relevant personnel of the product supplier immediately.

2.2.5 Storage

After receiving the product, please store it properly according to the following requirements.

Table 0-2 Requirements on Equipment Storage

Contents	Requirements
Storage environment	Safe and clean (dust-free, etc.)
Storage temperature	-40°C~70°C
Storage humidity	<95%RH (no condensation)
Storage time	The total transportation and storage time shall not exceed 6 months, and the performance shall be recalibrated after 6 months.

[Warning: 1. If the equipment has been unpacked, it must be repackaged according to the original packaging requirements;

2. Long-term exposure to the external environment after the equipment is taken out may lead to damage and the manufacturer's warranty will be invalid.]

Chapter 3 Installation

Summary - This Chapter mainly introduces the installation place, installation form, mechanical installation and electrical installation, etc.

3.1 Installation Place

In order to install the unit conveniently and run it in the best condition, users should consider the relevant factors of the installation site to ensure that the room and outdoor environment meet the use requirements before installing the equipment.

Consideration factors

1. Ensure that there is enough space at the bottom of the cabinet to ensure smooth air inlet of the condenser;
2. Ensure that the condensation air inlet is not blocked;
3. Ensure that the air inlet and outlet of the air conditioner circulation have good heat insulation measures;
4. Ensure that the cold and hot passages of the cabinet have good heat insulation measures;
5. Carry out heat preservation and sealing treatment on the cabinet of the micro-module data center, so as to avoid dust from entering, prevent heat leakage and moisture leakage and reduce heat load to the maximum extent;
6. Ventilation or heat dissipation conditions are required in the machine room to ensure the heat dissipation of the air conditioner condenser.

[Description:

- a) The above is for reference only. Please hire professionals to design according to the site conditions and relevant specifications.
- b) The VCS integrated rack precision air conditioner is only applicable to cabinets with a depth greater than or equal to 1100mm and a width greater than or equal to 600mm. For special cabinet installation requirements, please contact INVT Technical Service Department.
- c) In order to ensure smooth air inlet of external circulation, the overall height of the cabinet from the ground should be kept at a certain distance, and it is recommended that it be no less than 80mm.]

[Note: When the actual total load of the server corresponding to a single air conditioner is less than 50% of the refrigerating capacity of the air conditioner or the cabinet tightness is not good, the humidity in the cabinet may be too high, which is not within the product quality category. It is recommended to check the cabinet tightness.]

3.2 Mechanical Installation

3.2.1 Installation Mode

1. Install guide rail at the bottom of both sides of the cabinet, and fix the front and rear ends of the guide rail with screws as shown in Fig. 3-1;
2. Push the air conditioner into the cabinet along the guide rail as shown in Fig. 3-2;
3. The air conditioner is pushed into the bottom of the cabinet along the guide rail and fixed with screws, as shown in Fig. 3-3.

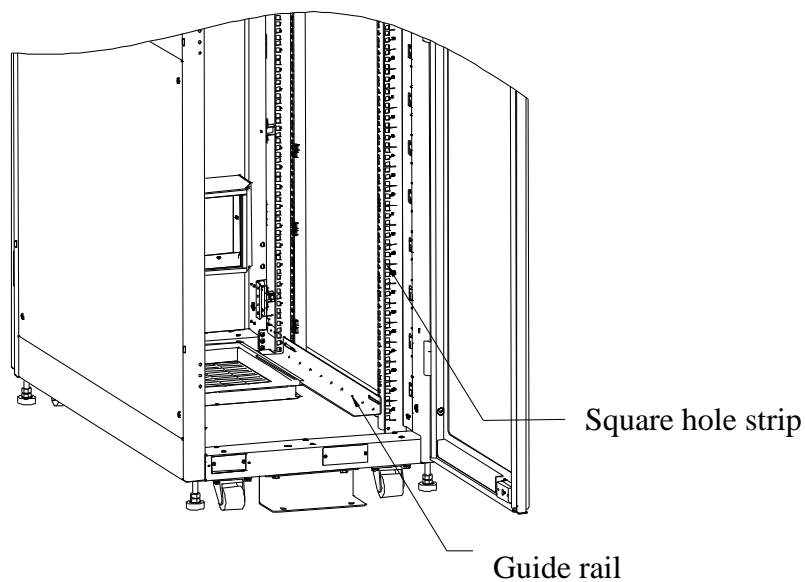

Fig. 0-1 Diagrammatic Sketch of Step 1

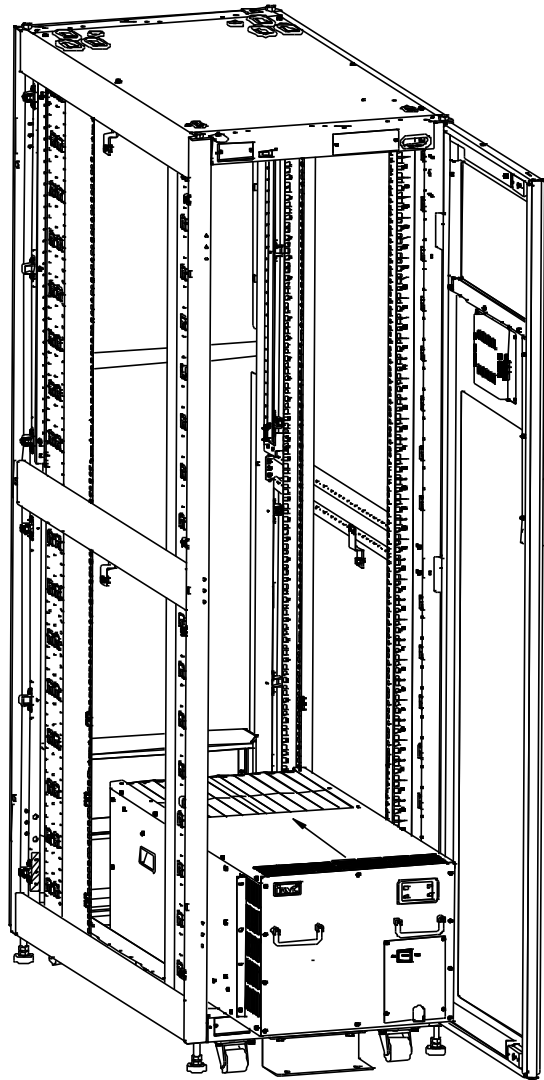

Fig. 0-2 Diagrammatic Sketch of Step 2

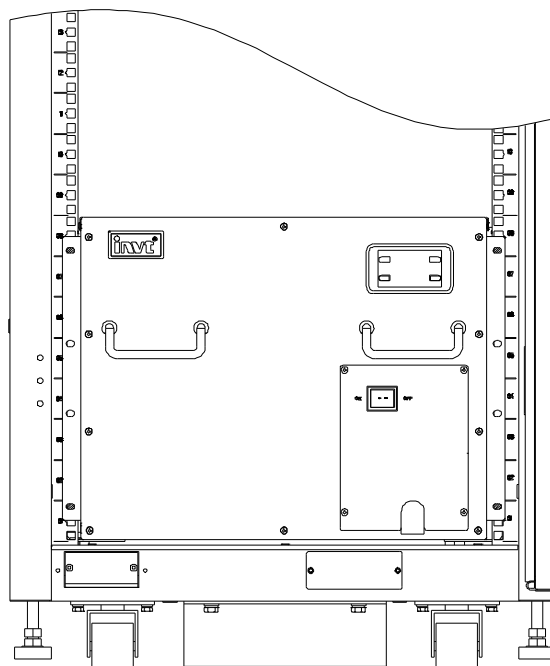
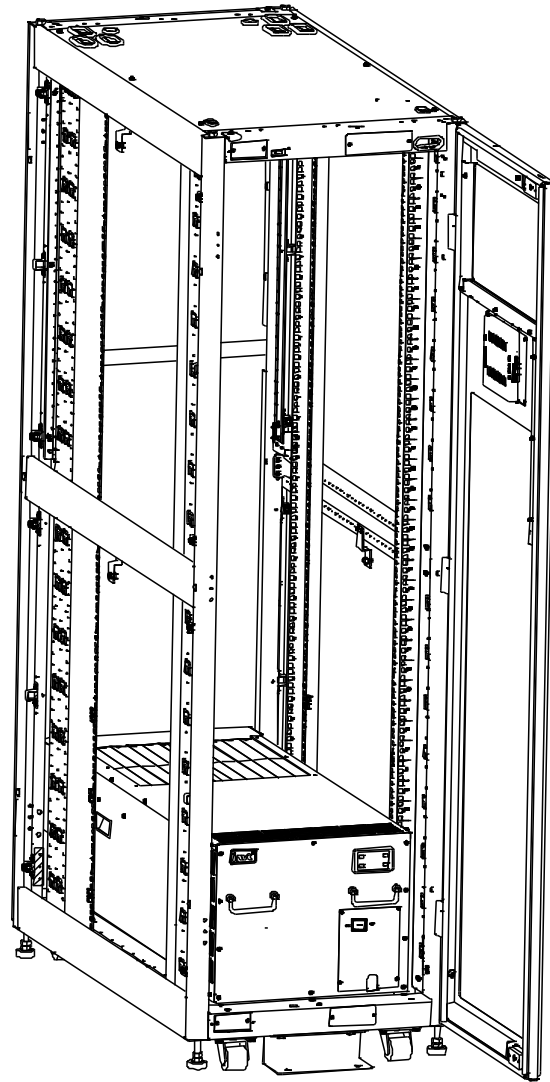

Fig. 0-3 Diagrammatic Sketch of Step 3

3.3 Installation of Other Components

3.3.1 Installation of Sealing Assembly

After fixing the air conditioner, the air outlet and air inlet of the external circulation of the air conditioner must be sealed with the cabinet to avoid affecting the performance of the air conditioner due to the intersection of cold and hot air flows, as shown in Fig. 3-4.

[**Note:** The sealing assembly is not the standard accessory of the air conditioner. Please refer to the size marked in Fig. 1-3 and Fig. 1-4 to manufacture the sealing assembly.]

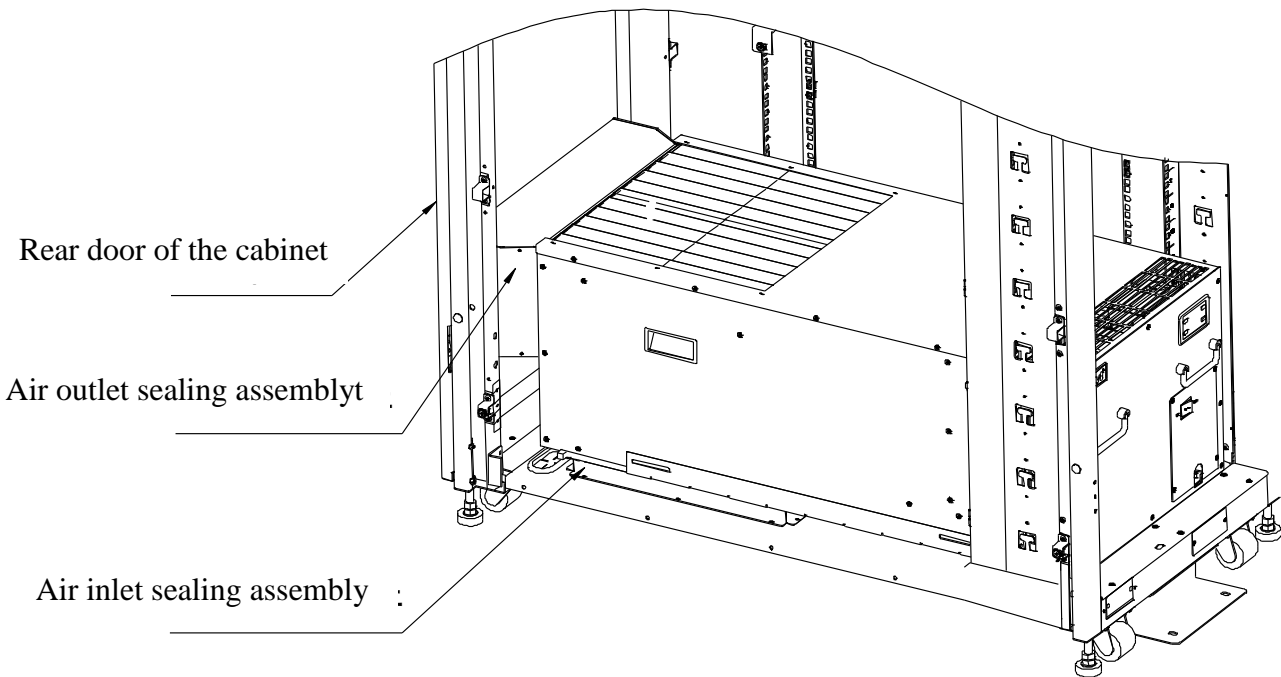

Fig. 0-4 Diagrammatic Sketch of Air Outlet Sealing of External Circulation

3.3.2 Installation of the Drainage Pipe

Connect the one-way valve in the accessory to the unit drain pipe, and then connect it with the on-site drainage pipe, so as to realize drainage.

[**Notices:**

1. The standard length of unit flexible pipe is 350mm, which can be added on site according to actual application;
2. One-way valve must be connected in the indicated direction, as shown in Fig. 3-5.
3. See Table 3-1 for the specification of the standard flexible pipe;
4. This model does not have a standard drainage pump, and it needs gravity drainage by height difference.

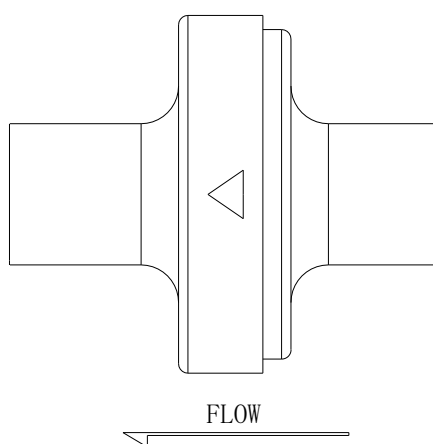
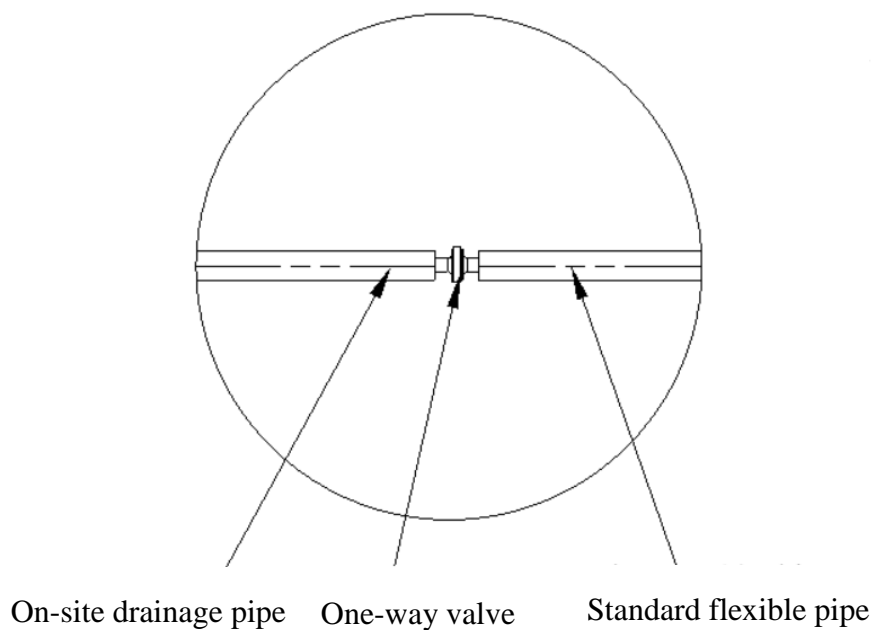

Fig. 0-5 Diagrammatic Sketch of the Installation Direction of One-way Valve

Table 0-1 Specification of Drainage Pipe and One-way Valve

Model	Drainage pipe (internal diameter × external diameter)
VCS003UH****	Ø10×Ø14mm

3.4 Electrical Installation

Operation Items

1. The main power line connection of the unit;
2. Communication line connection.

Precautions

1. The connection of all lines must comply with the provisions of the state;
2. Please refer to the equipment nameplate for the full load current of relevant units;
3. The main power supply meets the unit requirements. Please refer to the equipment nameplate;
4. Electrical installation must be carried out by qualified professionals;
5. Measure the input power supply voltage with voltmeter before connecting the circuit to make sure that the power supply has been turned off.
6. The full load current of the air conditioner is 13.5A, and the recommended wire diameter of power line should be no less than 2.5mm ?
7. The main power supply end of the air conditioner should be connected to fixed wiring by a set of power flexible wires, and must be equipped with an all-pole disconnecting device with the distance of bottoming point under overvoltage III according to wiring rules, and confirm whether its rating is appropriate.

Inspection

1. Make sure that the wiring cables are connected correctly;
2. The power supply voltage is consistent with the rated voltage on the equipment nameplate;
3. All connections are fastened;

Wiring Diagram

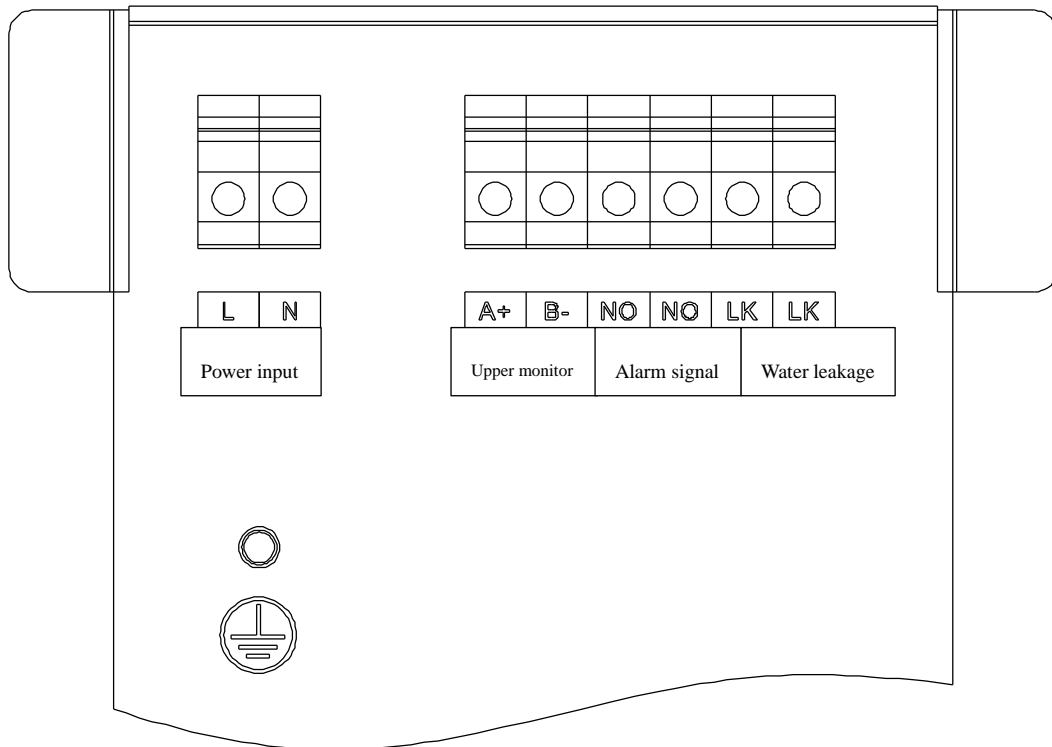

Fig. 0-6 Diagrammatic Sketch of the Wiring of Electric Control Box

Description of Graphic Expression

Fig. 3-6 Description of terminal board wiring:

- a) The main power line shall be connected according to L/N, and the PE line shall be connected to the ground wire hole;
- b) NO/NO is a reserved terminal for fault output. If you need to use this function, you can directly connect the corresponding terminal. NO is the normally open contact of relay, and the corresponding relay specification is 250VAC/3A or 30VDC/3A, and the relay cannot be connected to inductive loads, such as compressors and fans;
- c) A+/B- is the RS485 monitoring terminal reserved for the upper computer. If you need to use this function, you can directly connect the corresponding terminal;
- d) LK/LK is a reserved terminal for water leakage output. If you need to use this function, you can directly connect the corresponding terminal.

Chapter 4 Controller

Summary - This Chapter mainly describes the functions and characteristics of the controller, display screen, control keys, switch operation, status query and user settings, etc.

4.1 Functions and Characteristics

The rack air conditioner adopts advanced micro-processing controller, which can achieve the purpose of precise temperature control and humidity control, and can ensure the stable and reliable operation of the unit. The controller stores programmable control programs and all operating parameters, which can be viewed through the display screen.

Functions and Characteristics:

1. Have the functions of power on auto-start and delay starting;
2. Have remote power-on function;
3. Have the function of multi-level password protection to prevent misoperation;
4. Allow manual operation of main components;
5. Integrated RS485 communication port supports remote monitoring and remote power-on/off unit.

4.2 Display Screen

The display screen adopts Chinese or English menu, which is composed of LCD screen and function keys. The display screen switches to the main page display 10s after power-on:

Return air temperature	30°C
Unit status	Close-down
System is normal	

The first line shows the current return air temperature;

The second line shows the unit status. “Running” is shown if the unit is turned on; “In close-down” is shown if the unit is in the close-down process; “Close-down” is shown if the unit is the close-down status; “Fault close-down” is shown if the unit is in fault close-down status (it can be started directly after fault reset), and “Manual” is shown if the unit is in manual state;





The third line shows the current system information. If there is no fault in the current unit, the “system is normal” is shown; if there is a fault, the specific fault name will be displayed in turn;





Fig. 0-1 Appearance Picture of SL109S Display Screen

4.3 Control Keys





Fig. 0-2 Description of Control Keys of SL109S Display Screen

Key	Meaning	Description on functions
	UP	<ol style="list-style-type: none"> 1) On any page, press this key for long time to return to the main page and press this key for short time to return to the previous page; 2) Press this key for long time on the main page to display the main version information; 3) Press this key for short time on the main page to view the system board and monitoring version; 4) In the parameter setting state, press this key for short time to set the parameter increase, and press this key for long time to set the fast parameter increase.
	DOWN	<ol style="list-style-type: none"> 1) If there is a “↓” prompt on any page, press this key to enter the next page; 2) In the parameter setting state, press this key for short time to set the parameter decrease, and press this key for long time to set the fast parameter decrease.
	ENT	<ol style="list-style-type: none"> 1) When on the main page, the faults eliminated outside this key can be reset; 2) When setting parameters, press this key to confirm the set parameters and automatically jump to the next parameter setting value; 3) Press “ENT” and “SET” together on the main page for long time to enter the password page, and enter the correct password to enter the manufacturer setting page.
	SET	<ol style="list-style-type: none"> 1) On the main page, press this key for short time to enter the main menu page; 2) On the page of setting parameters, press this key to set parameters and enter the setting state (highlighted); if there are no parameters to set in the current picture, perform a dummy operation; 3) Press “ENT” and “SET” together on the main page for long time to enter the password page, and enter the correct password to enter the manufacturer setting page; 4) Press this key for long time on the main page to start and close the unit.

4.4 Power-on/off Operation





Press “” in the main interface, the unit will enter the operating state, and the unit status display on the interface will change from “Close-down” to “Operating”. If you press “” again, the unit will display “In close-down”; then, the unit is powered off after executing the close-down instruction “delay off time”, and “In close-down” is changed to “Close-down”.

4.5 Status Query







Press the “” on the main page to enter the “Main menu” page, and press “” to enter the setting status. At this time, the current function page option is highlighted, and press “” to enter the corresponding page. If it is “”, dummy operation shall be performed and it shall switch to the next function page. “Main menu” page is shown in the following figure:

User setting	Enter
Environment status	Enter
Equipment status	Enter
Protection status	Enter

4.6 User Setting

Press the “” on the main page to enter the “Main menu” page, and press “” to select user setting. At this time, the background of the current function page option is black, and press “” to enter the corresponding page. If it is “”, dummy operation shall be performed and it shall switch to the next function page. “User setting” page is shown in the following figure:

User setting	
Temperature point setting	30.0°C
Temperature control precision	3.0°C

On the setting page, press the “” key to enter the parameter setting status. At this time, the first set parameter is highlighted. Press the “” and “” keys to adjust the set value. Press the “” and “” keys for long time to rapidly “increase or decrease” adjusted set value. After setting, press “” key to confirm the set value and switch to the next set parameter. If “” key is pressed while

“←” is not, a dummy operation shall be performed; namely, the current set parameter is not saved and it is automatically switched to the next set parameter. Press “↑” to return to the main page when finished. Specific user settings are as follows:





Table 0-1 Scope of Use of User Parameters

Name	Value	Unit	Default	Meaning
Temperature point setting	24.0~50.0	°C	30.0	Temperature setting point
Temperature control precision	0.1~10.0	°C	3.0	Temperature control precision
High temperature alarm	20.0~80.0	°C	40.0	Setting of high temperature alarm point
Low temperature alarm	-10.0~20.0	°C	10.0	Setting of low temperature alarm point
Power on auto-start	Disabled / enabled	--	Enabled	Set the power on auto-start function
Language selection	Chinese/English	--	Chinese	Language selection
Contrast ratio adjustment	20~40	--	25	Adjust the contrast ratio of the display screen

4.7 Input/output View

On the “Main menu” page, you can enter the corresponding function pages to inquire about the current environment status, equipment status and fault protection status, as shown in the following figure:

Environment status		
Return air temperature		Unit: °C
Evaporation coil temperature		Unit: °C
Condensation coil temperature		Unit: °C
Supply air temperature		Unit: °C
Equipment status		

Compressor		
Blower		
External air fan	 is closed;  is opened	
Electrical heating		
Fault output		
Running time of compressor	0~30000	Unit: H
Running time of blower	0~30000	Unit: H
Running time of external air fan	0~30000	Unit: H
Running time of electrical heating	0~30000	Unit: H
Screen time	0~30000	Unit: H
Working state of unit	Standby / ventilation / refrigeration / heating / refrigeration and heating	
Protection status		
Smoke water leakage	 : input point is disconnected;  : input point is closed;	

4.8 Operation Logic

The VCS003UH operation logic is as follows:

➤ **Refrigeration mode**

After the blower turns on [Start delay time], the compressor can be turned on when the following conditions are met:

The compressor is turned on when the current temperature is \geq [temperature set point] + [temperature control accuracy];

The compressor is turned off when the current temperature is \leq [temperature set point].

➤ **Heating mode**

After the blower turns on [Start delay time], the electrical heating can be turned on when the following conditions are met:

The electrical heating is started when the current temperature is \geq [temperature set point] -

[temperature control accuracy];

The electrical heating is closed when the current temperature is \leq [temperature set point].

Chapter 5 Inspection and Commissioning

Summary - This Chapter mainly introduces the inspection, function inspection and system commissioning after the unit installation is completed.

5.1 Inspection

Inspection of Mechanical Installation

1. The installed fastening parts have been locked;
2. The drainage pipe has been connected;
3. After the equipment installation is completed, the sundries around the equipment have been removed (such as transportation materials, structural materials and tools, etc.);

Inspection of Electrical Installation

1. The power supply voltage is the same as the rated power supply on the equipment nameplate;
2. There is no open circuit or short circuit in the electrical circuit of the system;
3. All cables and circuit connectors have been fastened, and fastening screws are not loose.

5.2 Function Inspection

Tips

Please ensure that the unit has been strictly inspected as required before starting the unit.

Inspection Contents

- a) Inspect the voltage at the power connection point, and the voltage reading shall not exceed $\pm 10\%$ of the rated value of the nameplate;
- b) Check whether the display is abnormal after power-on;
- c) Inspect the control functions, such as temperature adjustment, of the unit.

Chapter 6 Maintenance and Fault Treatment

Summary - This Chapter mainly introduces the maintenance and fault treatment of the unit.

6.1 Daily Maintenance

1. Electric control system

- a) Dust the electrical and control components with a brush or dry compressed air;
- b) Check whether the quick connector is in good contact, and replace the terminal if it is found to be loose.

2. Indoor fan

- a) Confirm that there is no deformation of indoor fan net cover;
- b) Confirm that there is no damage to indoor fan blades;
- c) Confirm that there is no abnormality in the running sound of indoor fan;
- d) Confirm that the fixing screws for indoor fan installation are not loose or deformed.

3. Heater

- a) Confirm that the electric heating fixing is not loose;
- b) Confirm that there is no corrosion on the electric heating surface.

4. Return air filter

- a) Confirm that the return air filter is free of dirty blockage;
- b) Confirm that the return air filter is not damaged or deformed;
- c) Confirm that there is no operation timeout alarm for the return air filter;

5. Compressor

- a) Confirm that the compressor fastening is not loose;
- b) Confirm that the compressor running sound is normal;
- c) Confirm that the refrigerant pipeline is free of oil stains and rust;

6.2 Treatment of Common Faults

Common faults mainly include abnormal electrical connection, main device failure and refrigeration system failure, etc. See Table 6-1 for common faults and suggestions on treatment.

[Note: When the unit fails and cannot be simply eliminated, please contact the service department of

our company for technical support.]

[Warning: Only professional technicians are allowed to carry out maintenance operation on the unit.

Please pay special attention during power operation.]

Table 0-1 Alarm and Measures of Common Faults

Failure device	Fault	Possible reason	Treatment method
Whole unit	Unit does not start	Unit power is not connected	Check the input power supply
Fan	Fan does not operate	No fan control signal output	Check whether the fan wiring is accurate and whether it falls off or is loose
		Fan damage	Replace the fan
Compressor	Compressor does not operate	Compressor has no opening requirement	Check whether the refrigeration starting point is set reasonably
		External protector of compressor is disconnected	Check whether the compressor coil is open circuit
		Compressor damage	Check whether the coil is short circuit to ground or open circuit
	The noise of compressor is too large	Return liquid	1. Check whether the return air temperature is set too low 2. Check whether the air supply and return air systems are dirty and blocked
Poor lubrication		Add lubricating oil	
Heater	Electric heating function is failed	Electric heating overload	Check whether the blower works normally to ensure smooth airflow
		Electric heating fault	Replace electric heating
Filter screen	Cleaning filter screen alarm	The unit operation time has exceeded the filter screen maintenance time	Clean the filter screen, and reset the filter screen time
Temperature sensing probe	Return air temperature probe fault	The temperature probe is damaged or the terminal is loose	Check whether the terminal is loose and whether the temperature sensor is damaged
	Supply air temperature probe fault	The temperature probe is damaged or the terminal is	Check whether the terminal is loose and whether the temperature sensor is

		loose	damaged
	Evaporator temperature probe fault	The temperature probe is damaged or the terminal is loose	Check whether the terminal is loose and whether the temperature sensor is damaged
	Condenser temperature probe fault	The temperature probe is damaged or the terminal is loose	Check whether the terminal is loose and whether the temperature sensor is damaged
Refrigeration system	High temperature alarm	Return air temperature probe fault	Check and calibrate the temperature sensor
		Compressor does not work	Check the working state of compressor
		Unreasonable setting of high temperature alarm value	Reset the high temperature alarm value
		Dirty blockage of air return filter screen	Clean the filter screen
		Insulation measures are not in place	Check the sealing condition of inlet/outlet of external circulation
		Unit load design is too small	Check the sealing condition of the cabinet and add refrigeration equipment if necessary
	Low temperature alarm	Return air temperature probe fault	Check and calibrate the temperature sensor
		Unreasonable setting of low temperature alarm value	Reset the low temperature alarm value
		Electric heating does not work	Check the working state of electric heating
	Condensation high temperature alarm	Dirty blockage of air inlet of external circulation	Clean the air inlet of external circulation
		Failure of condensing fan	Check whether the condensing fan operates normally
		Overcharge of refrigerant amount	Discharge excess refrigerant, and control the high pressure of the system within the range of 2.6-3.2MPa
		Dirty blockage of condenser	Clean condenser

		fins	
Evaporator anti-freezing alarm		Refrigerant flow is low	Add the refrigerant charge after checking that there is no leakage
		Air volume is too small	Clean the return air filter screen
		The return air temperature is set too low	Increase return air temperature set point
		Dirty blockage of evaporator fins	Clean evaporator
Refrigerant shortage alarm		Refrigerant leakage	Maintenance personnel check whether there is any leakage in the system, and refill the refrigerant again after repairing the leakage
		Evaporator temperature sensing package is loose	Check whether the evaporator temperature sensing package is loose

Annex I Electrical Schematic Diagram

